



STRETCH WRAPPER
MODEL: CSR 9120

CSR 9120

The only machine with external pre-stretch drive system, without electric sliding contacts/ slip rings or other complex and expensive solutions like electric generator. Available for output capacity up to 140 pallet /h. Also available with double reels.

Technical Characteristics

Conveyor height std	500 mm +/- 50
Maximum ring rotation speed	65 rpm
Protection on electric system & motors	IP 54
Total power installed	12 Kw - 13 Kw with Top
Standard power supply	400V – 50 Hz – 3 PH+N+G
Operating pressure	6 bar
Pre-stretch ratio	Min. 160% - Max. 300%
Production capacity per h	Up to 120

Product Dimensions

Max pallet dimensions	1200 x 1200 mm 1300 x 1100 mm
Min pallet dimensions	600 x 800 mm
Std pallet height	2200 mm

PRE-STRETCH-SYSTEM

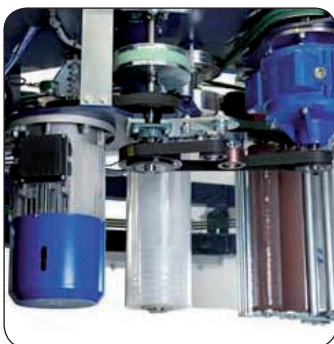

External pre-stretch dry system.

Patented system



Options

- Acid protection.
- For loads up to 3000 mm high.
- Pallet holder presser.
- Corner applicator.
- Roping system.
- Top cover.
- Pallet lifter.
- Jumbo reel.
- Automatic change reel.

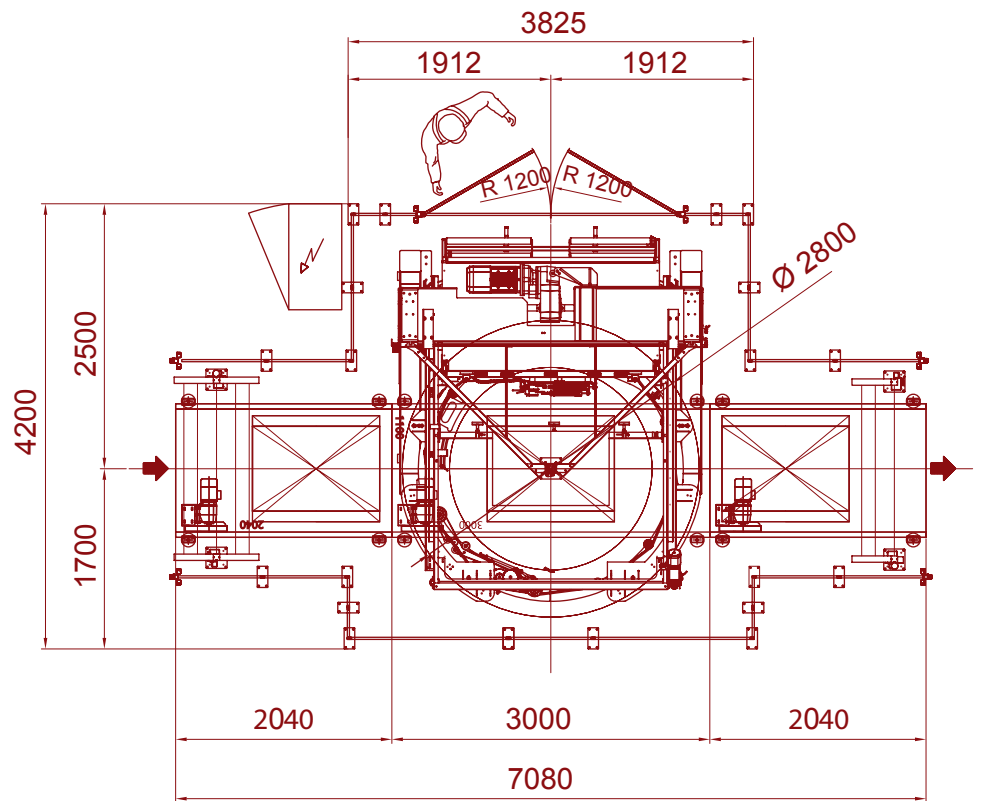

Control panel equipped in a standard version with a touch-screen operator Display.

140 pallets per hour

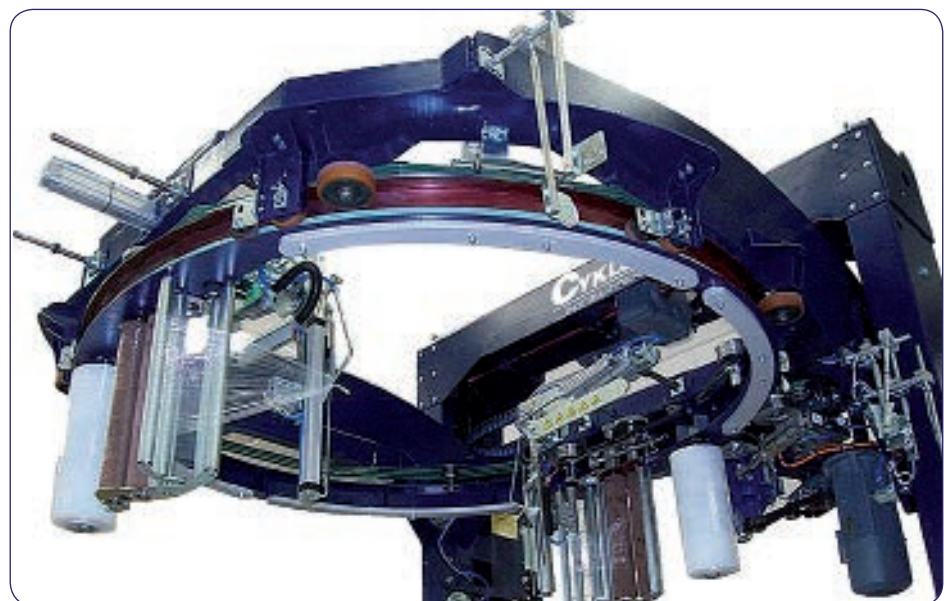

Double reels.

WWW.CYKLOP.NL
+31 384675800

CYKLOP Nederland BV
Benjamin Franklinstraat 5
8013 NC Zwolle
info@cyklop.nl

